

Overview

Retrofit Interior (RI) replaces existing relay panel electronics and relays with a single back plate mounted assembly. Installation retains the original line voltage wire, conduit, and enclosure reducing labor as well as material cost. RI may be scheduled from any BACnet BAS and is compatible with all low voltage switches, occupancy sensors, and light level sensors. Retrofit Interior 48 (RI48) may be specified with 24, 32, 40, or 48 Lighting Tough Relays (LTR) in addition to several special options.

Features

UL Listed

Retains line voltage wire, conduit, and enclosure

Switching and Dimming (DLH / Presets) models available

BACnet MS/TP communication to BAS network

Sub network for Satellite and Capacitive Touch Stations (CTS)

Install in less than 4 hours

Available options:

- 347VAC Transformer
- UL924 Emergency Bypass
- LEXP Digital Input Expansion Card
- Top, bottom, or center mount low voltage compartment

General Specifications

Construction: 16ga steel with galvanneal / powder coat finish

Dimensions:

Top / Bottom Low Voltage Compartment:

- 31.28"(795mm)H x 12.00"(305mm)W x 3.38"(86mm)D
- Factory mounted transformer increases overall width to 15.56"(395mm)

Center Low Voltage Compartment:

- 29.00"(737mm)H x 12.00"(305mm)W x 5.25"(133mm)D

Approximate Weight: 25lbs(11kg)

Mounting: Standard (1.00"(25mm) washer head self-tapping) Concrete / Masonry (2.25"(51mm) masonry screws with flat washer)

Operating Environment: 32-125°F (0-50°C), 20-95%RH, non-condensing

Certifications

UL Listed, UL508A Open, Standard for Energy Management Equipment, US/Canada

CEC Title 24

Electronics meet or exceed IEC Level 3

Warranty

Two (2) year limited manufacturer warranty from date of shipment (extended warranty optional).

Firmware Specifications (Controller Board)

Platform: Aperio Open Control Platform

Time Clock: Real-time clock with BACnet time sync

Schedule: BACnet Schedule, Monday – Sunday, Holidays, and Exceptions
Non-Volatile Memory: 16MB total, 2MB for trend data (15min trend requires 2K per day)

RAM: 2MB total, data stored in non-volatile memory upon power loss

Configuration: Tech Kit 2.0 (see data sheet for details)

Configuration Connection: Micro-B USB or Bluetooth Wireless

Low Voltage Specifications (Controller Board)

Power In: 24VAC +/-10%, 30VA, 50-60 Hz

Auxiliary Out: 24VAC, 800mA (devices with full wave rectified power supply only)

Universal Input (UI) and Satellite / Station Network Power Out: 24VDC, 200mA total

Universal Input: 24 two-wire inputs

Universal Input Software Configuration:

Digital Input (DI)

Analog Input (AI): 0-5VDC, 0-10VDC, or 4-20mA

Universal Input Wire Requirement / Maximum Length: 18AWG (Solid or Stranded) / 500'(152m)

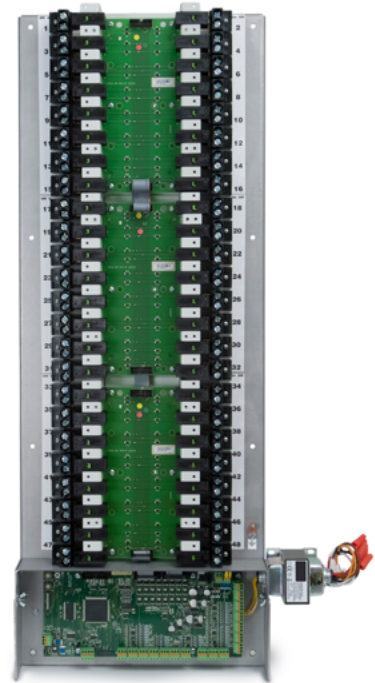

BAS Network Specifications

Protocol: BACnet MS/TP

Baud Rate: DIP switch selectable 9.6K, 19.2K, 38.4K, 76.8K, or 115.2K

Device Profile: BACnet Advance Application Controller (AAC)

Address Range: 1 – 99 selectable with rotary dials

Unit Load: 1/8 unit load

Topology: RS-485, half duplex, daisy chain wiring

Wire Requirement / Maximum Length: CL3P, 22AWG, 2 conductor, shielded, low cap / 4000'(1216m)

Points: See *PIC Statement*

Satellite / Station Network Specifications

Compatible with CTS and Satellite devices. See data sheet for details.

Transformer Specifications

Type: 40VA Inherently Limited UL Listed

Primary: Multi Tap 120, 208, 240, or 277VAC +/-10%, 40VA, 50-60 Hz

Secondary: 24VAC +/-10% Inherently Limited

Wire Requirement: 18AWG Minimum (Solid or Stranded)

The transformer is factory installed in the Exclusion Frame. However, a knockout bushing is included to facilitate remote mounting applications.

LTR Specifications

Type:

UL Listed

SPST latching with manual override lever

Electrically operated mechanically held, pulse driven

Short Circuit Current Rating (SCCR) 30,000A @ 277 VAC

Maximum Ratings: Tungsten 20A @ 347VAC / Ballast 30A @ 347VAC /

Resistive 20A @ 347VAC / 1.5HP @ 120VAC

Load Terminal: Universal screw terminal, box type clamp

Terminal Capacity (per side): (2) 14-10AWG or (1) 8AWG (Solid or Stranded copper wire)

Optional Equipment Specifications

See Retrofit Interior Optional Equipment Data Sheet

Retrofit Interior 48

General Architecture

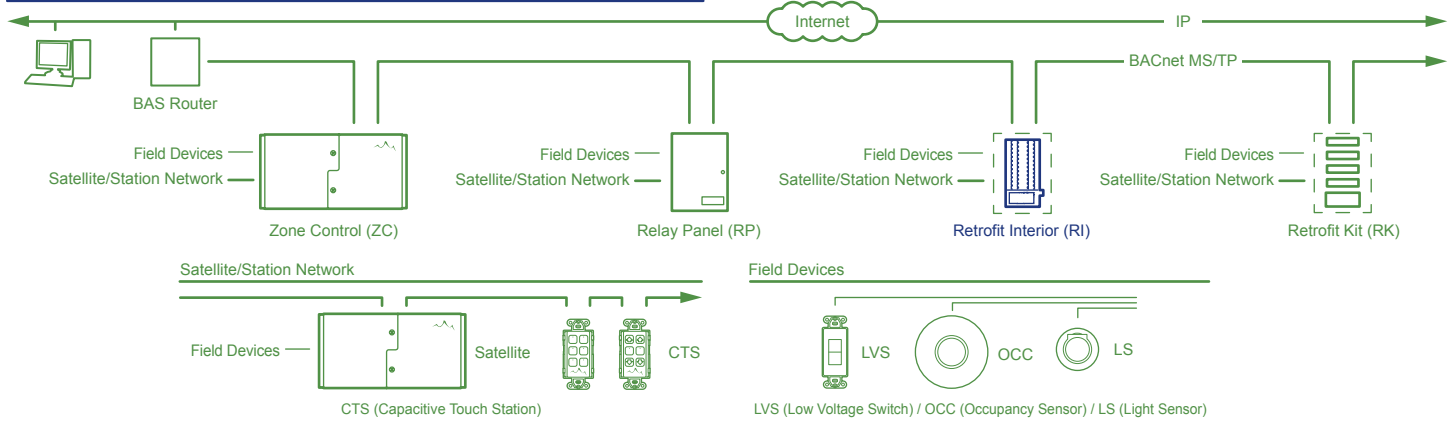

Controller Board Terminations

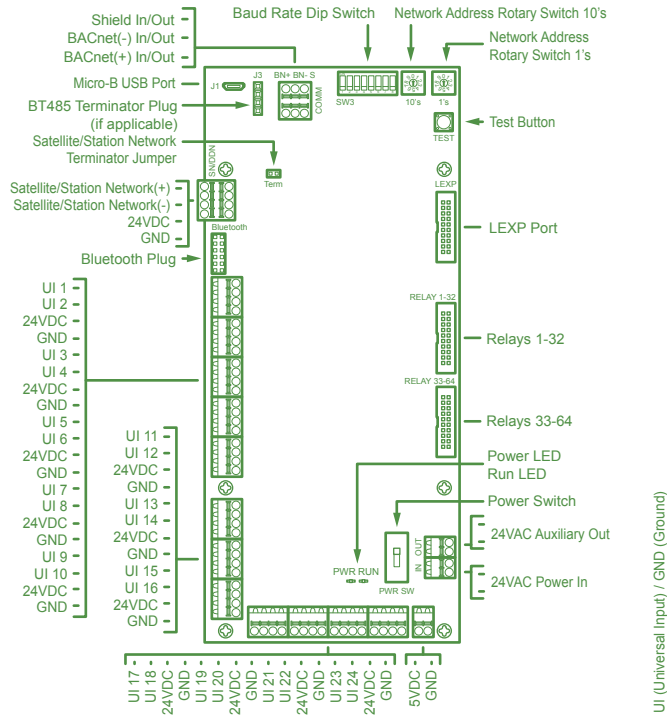

Transformer Terminations

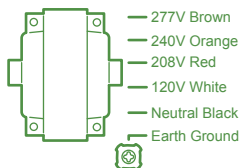

LTR Terminations

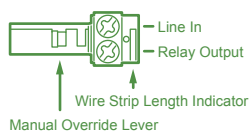

Ordering Information

RI XX 48 - XX - X - XX - XX

